

DIN 卡套式管接头

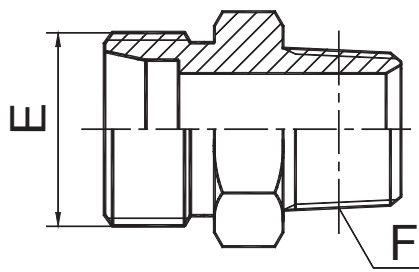

1CN
1DN

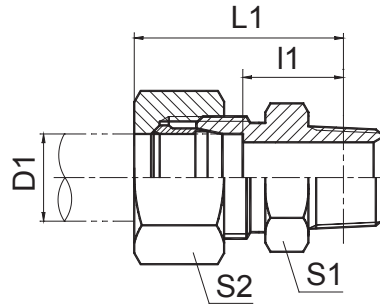

1CN-RN
1DN-RN

布锥管外螺纹
NPT MALE

代号 PART NO.	螺纹 THREAD		管子外径 TUBE O.D. D1	尺寸 DIMENSIONS				压力等级 MPa
	E	F		l1	L1	S1	S2	
1CN-08-02	M8X1	Z1/8"X27	4	14.4	24.4	11	10	10 特轻系列 LL
1CN-10-02LL	M10X1	Z1/8"X27	6	12.9	24.4	11	12	
1CN-12-02LL	M12X1	Z1/8"X27	8	13.9	25.4	12	14	
1CN-12-02	M12X1.5	Z1/8"X27	6	13.4	28.4	12	14	31.5 轻系列 L
1CN-12-04	M12X1.5	Z1/4"X18	6	17.2	32.2	17	14	
1CN-14-04	M14X1.5	Z1/4"X18	8	17.2	32.2	14	17	
1CN-16-04	M16X1.5	Z1/4"X18	10	18.2	33.2	17	19	
1CN-16-06	M16X1.5	Z3/8"X18	10	19.9	53.0	19	19	
1CN-18-04	M18X1.5	Z1/4"X18	12	19.2	34.2	19	22	
1CN-18-06	M18X1.5	Z3/8"X18	12	19.9	34.9	19	22	
1CN-18-08	M18X1.5	Z1/2"X14	12	21.4	36.4	22	22	
1CN-22-08	M22X1.5	Z1/2"X14	15	22.4	37.4	24	27	
1CN-22-20	M22X1.5	Z1.1/4"X11.5	15	29.8	37.4	46	27	
1CN-26-08	M26X1.5	Z1/2"X14	18	22.9	39.4	27	32	16 轻系列 L
1CN-26-12	M26X1.5	Z3/4"X14	18	22.4	38.9	30	32	
1CN-30-08	M30X2	Z1/2"X14	22	24.4	40.5	32	36	
1CN-30-12	M30X2	Z3/4"X14	22	24.4	40.9	32	36	
1CN-36-16	M36X2	Z1"X11.5	28	29.8	46.3	41	41	
1CN-36-20	M36X2	Z1.1/4"X11.5	28	31.3	46.3	46	41	
1CN-45-20	M45X2	Z1.1/4"X11.5	35	30.3	51.8	46	50	
1CN-52-20	M52X2	Z1.1/4"X11.5	42	31.8	55.8	55	60	
1CN-52-24	M52X2	Z1.1/2"X11.5	42	32.8	55.8	55	60	
1DN-14-04	M14X1.5	Z1/4"X18	6	22.2	37.2	17	17	
1DN-16-04	M16X1.5	Z1/4"X18	8	22.2	37.2	17	19	
1DN-18-04	M18X1.5	Z1/4"X18	10	21.7	38.2	19	22	
1DN-18-06	M18X1.5	Z3/8"X18	10	22.4	38.9	19	22	
1DN-20-04	M20X1.5	Z1/4"X18	12	23.7	40.2	22	24	
1DN-20-06	M20X1.5	Z3/8"X18	12	24.4	40.9	22	24	
1DN-20-08	M20X1.5	Z1/2"X14	12	25.9	42.4	22	24	
1DN-22-08	M22X1.5	Z1/2"X14	14	27.4	45.4	24	27	
1DN-24-08	M24X1.5	Z1/2"X14	16	26.9	45.4	27	30	
1DN-30-12	M30X2	Z3/4"X14	20	28.4	49.9	32	36	
1DN-36-12	M36X2	Z3/4"X14	25	30.9	34.0	41	46	40 重系列 S
1DN-36-16	M36X2	Z1"X11.5	25	35.3	59.3	41	46	
1DN-42-16	M42X2	Z1"X11.5	30	35.8	59.3	46	46	
1DN-42-20	M42X2	Z1.1/4"X11.5	30	36.3	62.8	46	50	
1DN-52-24	M52X2	Z1.1/2"X11.5	38	39.8	70.8	55	60	

注：如需带卡套及卡套螺母整套订货，则请在代号后加“RN”，如10N-30-12RN。

Note: In case if you are interested to order the adapter in complete set with cutting ring and nut, it is necessary to insert suffix "RN" after our part no., for example 10N-30-12RN.